



This document provides installation instructions for the QUANTAPANEL 600 Series Architectural Low-E Storm Window System.

To simplify installation, make sure your measurements are completely accurately using the Measurement Guidelines for QUANTAPANEL 600 Series.

Installation Guidelines

1. Inspect the **QUANTAPANEL 600 IGS** prior to installation, and measure the window opening to ensure the correct QUANTAPANEL unit for the window opening.
2. After inspection, place the **QUANTAPANEL 600 IGS** into the opening firmly against the prime window stop. Check to ensure that a minimum $\frac{3}{4}$ inch space exists between the **QUANTAPANEL IGS** and prime window if possible, to allow for easy locking/unlocking of the prime window (typically at the meeting rail). Square up with shims as necessary.
3. Once the **QUANTAPANEL IGS** is in place and is squared up in the opening, raise and lower the sashes to ensure they move freely.
4. After making sure the sashes mover freely, you are ready to attach the **QUANTAPANEL 600 IGS** using the installation screws provided. Remove the sashes if necessary to facilitate installation. For the QUANTAPANEL 604/606 (3-Track) Models, the install holes are located in the center track. For the QUANTAPANEL 605/607 (2-Track) Models, the install holes are in the track closest to the prime window. The installation holes are pre-drilled and located a few inches below the head, and a few inches above the sill. Large windows may have additional pre-drilled installation holes near the center. Tighten firmly, **BUT DO NOT OVERTIGHTEN**.

5. Once the install screws are in place, reinstall the sashes and check to make sure that the sashes still move freely. If the sashes do not move freely, it may be necessary to adjust the installation screws and ensure that the **QUANTAPANEL 600 IGS** is squared up.
6. The compressible bulb seal on the exterior of the frame is designed to create a seal with the existing window jamb, and allow for any slight out-of-square condition in the existing jamb. After making sure the sashes move freely, cut excess material off of the shims, and remove any excess bulb seal at the corners. Apply a **butyl, silicone or elastomeric caulking compound** around the perimeter. If there is a large gap between the prime window jamb and the jamb of the **QUANTAPANEL 600 IGS**, a caulk backer is recommended to fill any excessive gaps before caulking.
7. Once the perimeter is caulked, you can install the finish trim stop. A ½ x ½ inch square stop is provided with the **QUANTAPANEL 600 IGS**. Measure and cut the four pieces to the correct dimension. Using trim nails, firmly nail the pieces in place. If a more decorative trim piece is desired, you can purchase various types of trim stock at a local lumber supply store and utilize this in lieu of the ½ x ½ inch square stop provided.
8. You are now ready to use and enjoy your interior **QUANTAPANEL 600 Architectural Low-e Storm Window**.

Schematic of QP600 IGS installed in Frame
(Installation Clip Not Shown)

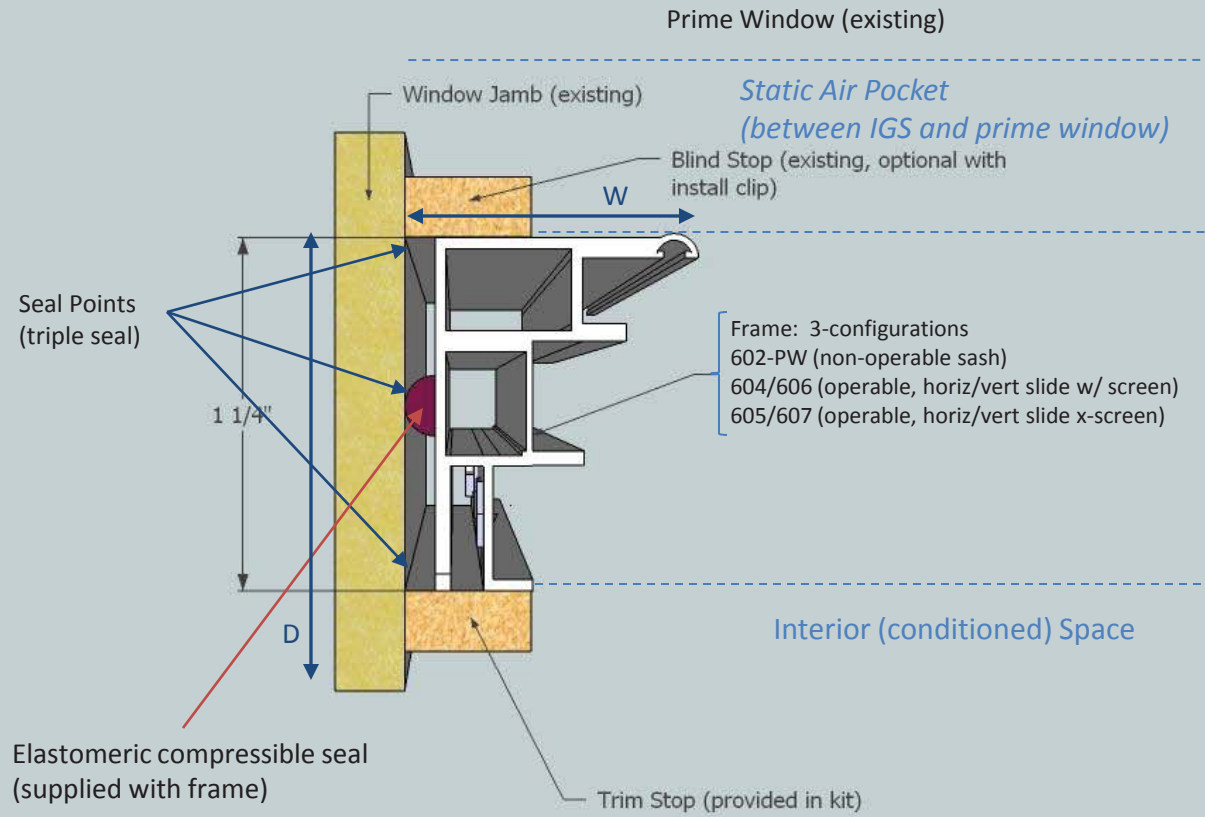

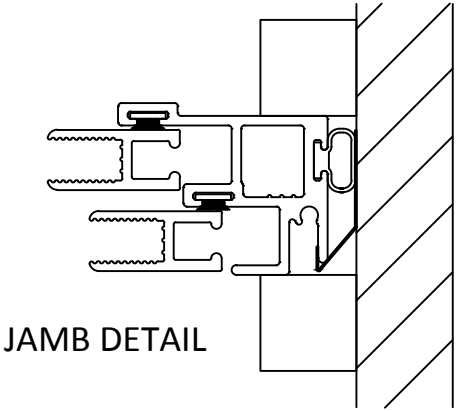
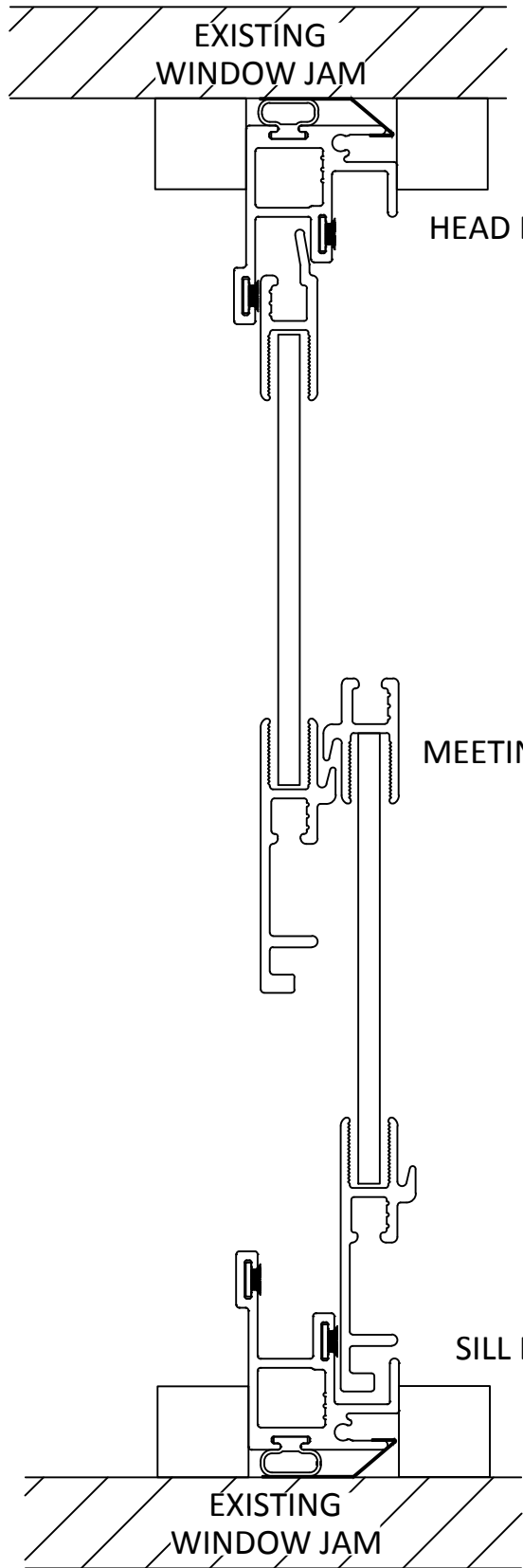

QUANTAPANEL®

605-DH INSULATING GLASS SYSTEM
 FRAME ASSEMBLY
 (DETAIL - INSTALLED)

NOTES:

DATE
SCALE
DRAWN BY